

Comparative Analysis of RNA Tumor Virus Genomes

Haseltine, W. A., Pedersen, F. S., Sahagan, B. G., Rosenberg, Z. F., Kozlov, J.

Sidney Farber Cancer Institute, 44 Binney Street, Boston, Ma 02115, USA

Introduction

Comparative structural analysis of RNA tumor virus genomes is relevant to several questions regarding the biology of these viruses and their role in neoplastic disease. We have recently developed and applied procedures that facilitate such studies. Using these methods we have studied murine, primate, feline and avian C-type viruses. In some cases our studies permit direct comparison of the nucleotide sequence.

The questions investigated that will be discussed here include:

1. The relationship amongst viruses isolated from the AKR mouse. Viruses that differ in oncogenic potency and in host range have been isolated from the tissues of AKR mice. A comparison of the structure of the Akv virus, an ecotropic N-tropic virus that forms plaques in the XC test (XC⁺) with that of a xenotropic AKR virus is presented. The structure of an ecotropic, N-tropic XC⁻ virus produced by lymphoid cell lines established from spontaneous AKR thymomas is also described. These studies structurally define a new class of AKR virus.

2. The sequence relationship amongst primate viruses of the woolly-gibbon group. Analysis of the structure of four independent isolates of gibbon ape C-type viruses and an isolate from a woolly monkey are presented.

The structure of a virus isolated from a patient with acute myelogenous leukemia (HL23) that has previously been shown to be related to the woolly monkey isolate is also investigated.

3. The sequence relationships among viruses of the feline leukemia group (FeLV): This work shows that these isolates are very closely related; the sequence of at least half the genome is identical.

4. The relationships between the transformation defective and non-defective Rous Sarcoma virus PrB is investigated. Sequence information of portions of the genome that code for the transformation function and for the structural genes is presented.

Results

A Micromethod for Detailed Characterization of High Molecular Weight RNA

We have developed a method for detailed studies of high molecular weight RNA available in small quantities. The procedures (Detailed methods are giv-

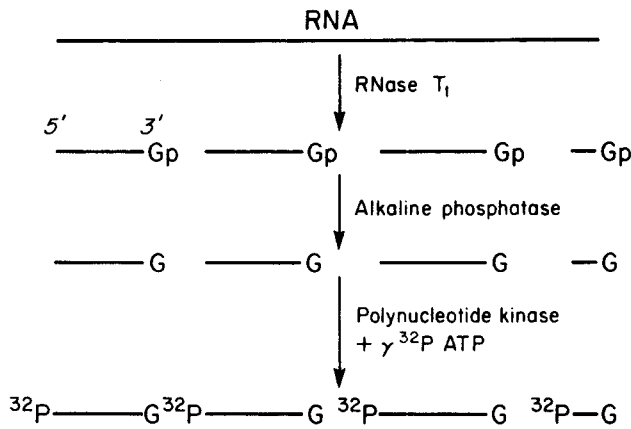

Fig. 1. Diagram showing the enzymatic reactions used for characterization of viral RNA

en in Pedersen and Haseltine, 1978 and diagrammed in Fig. 1) involve specific cleavage of a small amount of *non-radioactive* RNA after guanosine residues by ribonuclease T₁ followed by 5'-³²P-labelling of the T₁ resistant oligonucleotides. The mixture of 5'-³²P-labelled oligonucleotides is then fractionated by two-dimensional gel electrophoresis. By autoradiography of the gel these oligonucleotides will show a pattern (termed a RNase T₁ fingerprint) which is characteristic for each RNA sample. For further analysis the unique oligonucleotides can be eluted and their nucleotide sequence determined using recently developed methods for RNA sequencing that depend upon partial digestion of 5' end-labelled RNA with ribonucleases that cleave the RNA at specific nucleotides (Donis-Keller et al., 1977).

When these procedures are applied to 200–400 ng of an RNA species about 10,000 nucleotides long, each T₁ resistant oligonucleotide will be labelled with ³²P at about 100,000 dpm. Our high resolution gel electrophoresis system makes it possible to isolate 50–80 pure unique T₁ resistant oligonucleotides from viral RNA. The amount of radioactivity in each oligonucleotide is sufficient for complete nucleotide sequence determination. The total sequence information thus obtained from less than 1 μg of RNA corresponds to 10–15% of the entire RNA molecule.

The AKR Viruses

The AKR strain of mouse was bred for high incidence of leukemia. Between 6 to 12 months of age AKR mice develop thymic leukemia. Genetic, virological and biochemical studies have demonstrated that a number of genetic factors are involved. These include two genetic loci that encode the information for the Akv virus (for a review see Tooze, 1973, and Rowe, 1973). The viruses (Akv-1, Akv-2) produced by these two loci are identical or very closely related (Rommelaere et al., 1977). Early in the life of the mouse, this virus appears in the tissues of the developing embryo. The mice remain viremic throughout their life. This virus, the Akv virus, is an ecotropic, N-tropic, XC⁺ virus. It does not induce disease when injected into newborn C3Hf (N-tropic mice) nor does it accelerate the time of onset of thymic leukemia when injected into newborn AKR mice (Nowinski and Hays, 1978).

The relationship of this virus to the ultimate event of transformation of the thymic lymphocytes remains unclear. Although the virus itself is not oncogenic, its expression is correlated with the induction of the disease since strains of AKR that do not produce the AKR virus do not develop spontaneous thymic leukemias at a high frequency (Rowe, 1973).

A further complexity is presented by the observation that the virus is present from very early times in the mouse life but that leukemia develops only later.

Recently several viruses with biologic properties different from those of the Akv virus have been isolated from the tissues of leukemic or pre-leukemic AKR mice. These include xenotropic viruses, viruses that do not grow on cells of murine origin, and polytropic viruses, viruses that grow on both cells of heterologous species and murine origin (Kawashima et al., 1976; Hartley et al., 1977). The polytropic viruses (also called MCF viruses because they have been observed to cause cytopathic effects on mink cells) have been isolated by growth of extracts of AKR leukemic and pre-leukemic tissues on mink cells. The biologic and biochemical properties of these viruses resemble those of recombinants between a xenotropic virus and the Akv virus. The glycoprotein of these viruses have tryptic peptides that are characteristic of both the ecotropic and xenotropic murine viruses (Elder et al., 1977). Moreover, analysis of the genome by mapping of the T_1 resistant oligonucleotides and by heteroduplex analysis shows that these polytropic viruses differ from the ecotropic viruses by a substitution of genetic information in the 3' region of the genome, the region in which is suspected to encode the glycoprotein. However, a simple model for the genesis of these viruses via a recombination between two parental virus appears to be excluded by the observation that the sequence of the substituted region differs for independent isolates (Romme-laere et al., 1978, and see below).

The appearance of these viruses in extracts of leukemic tissues has prompted speculation that they might be the transforming agents. However, whereas some of these viruses accelerate the appearance of thymic leukemia when injected into newborn AKR mice, others do not (Nowinski and Hays, 1978).

Recently another family of viruses have been isolated from the tissues of AKR mice. These are the viruses produced by lymphoid cell lines established in culture from the thymus of leukemic mice (Nowinski et al., 1978). The virus produced by 5 of 8 of these spontaneous leukemia cell lines (SL1, SL2, SL3, SL7, SL8) is ecotropic, N-tropic XC⁻. Two other lines produce either a polytropic (SL4) or xenotropic (SL5) virus in addition to the ecotropic N-tropic XC negative virus and one produces an ecotropic, NB-tropic virus in addition to a polytropic virus (SL6). Some of these viruses accelerate the appearance of thymic disease when injected into the newborn AKR mice (SL1, SL2, SL3, SL4, SL6) and others do not (SL5, SL7, SL8) (Nowinski and Hays, 1978).

In order to understand the relationships among this complex family of virus with the eventual goal of understanding leukemogenesis in terms of the structure of the viruses, we have begun a detailed characterization of the genomes of those viruses using the techniques of T_1 oligonucleotide mapping and sequence analysis described above.

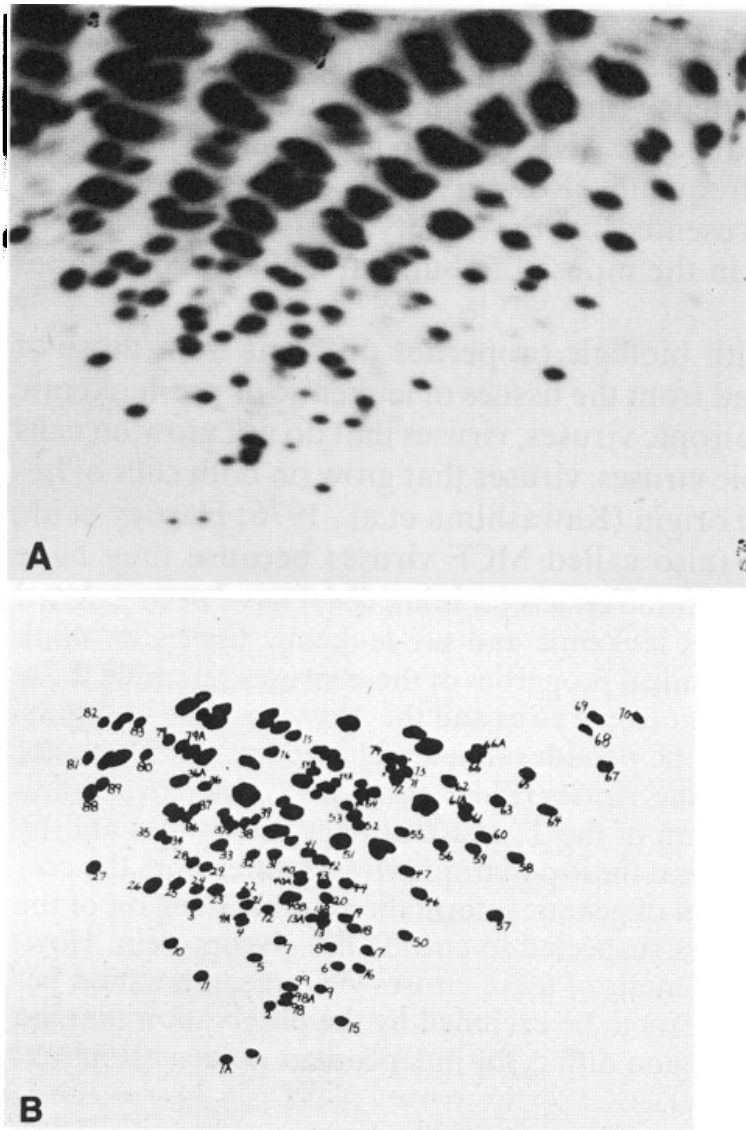

Fig. 2. *A.* RNase T_1 fingerprint of RNA from Akv virus. *B.* Schematic diagram of this fingerprint

Our point of departure has been to characterize the structure of the Akv virus genome in detail. The fingerprint of the RNA loci of this virus is presented in Fig. 2 together with a schematic representation in which each unique oligonucleotide has been assigned a number. This virus produced by an AKR embryo fibroblast cell line may be a mixture of two viruses that differ very slightly in the sequence. By sequence analysis the two oligonucleotides 1 and 1A are found to differ by only a single nucleotide. The method used to determine the sequence of the oligonucleotides is illustrated in Fig. 3. The 5' labelled oligonucleotide is divided into aliquots which are partially digested with different base specific ribonucleases. The ribonuclease cleavage sites are then mapped by electrophoreses on a polyacrylamide gel under denaturing conditions (Donis-Keller et al., 1977).

The order of the T_1 resistant oligonucleotides can be determined by analysis of the fingerprints of poly A selected fraction of genomic RNA of different length. The oligonucleotides present in short poly A containing RNA are clos-

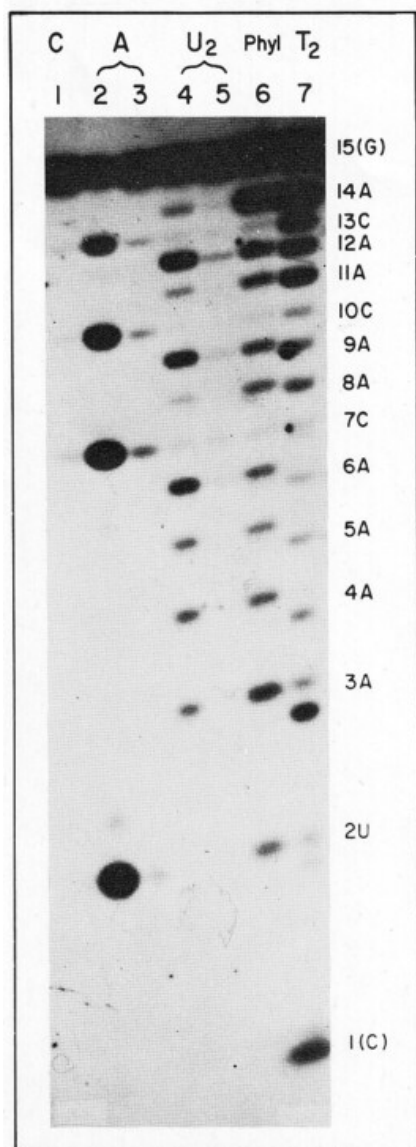

Fig. 3. Autoradiogram of polyacrylamide gel used for nucleotide sequence determination of a RNase T₁ resistant oligonucleotide. The following samples were loaded onto the gel.

No. 1: Unfragmented oligonucleotide; nos. 2 and 3: Oligonucleotide partially digested with RNase A (cleaves after U and C residues); nos. 4 and 5: Oligonucleotide partially digested with RNase U₂ (cleaves after A residues); no. 6: Oligonucleotide digested with Phyl RNases (cleave after A and U); no. 7: Oligonucleotide partially digested with RNase T₂ (cleaves after all residues)

est to the 3' end of the genome. We have fingerprinted several size classes of Akv-RNA that were selected to contain poly A by passage over an oligo dT-cellulose column. The order of the T₁ resistant oligonucleotides along the genome is given in Table 1. No order of the oligonucleotides within the brackets

Table 1. Ordering of T₁ resistant oligonucleotides on the Akv genome

Group No.	Nucleotide No.
I 5' region	(1, 1A, 2, 3, 5, 12, 15, 16, 21, 35, 38, 40A, 41, 43, 49, 54A, 59, 60, 81, 98)
II	(4, 6, 7, 13, 13B, 26, 28, 29, 37, 37A, 50)
III	(8, 9, 13A, 17, 20, 22, 24, 31A, 33, 39, 46, 64, 80)
IV	(10, 11, 18, 31, 40B, 40C, 44, 47, 56, 98A)
V 3' region	(68, 65, 69, 57, 42, 99, 55B, 63, 55A, 34, 25)

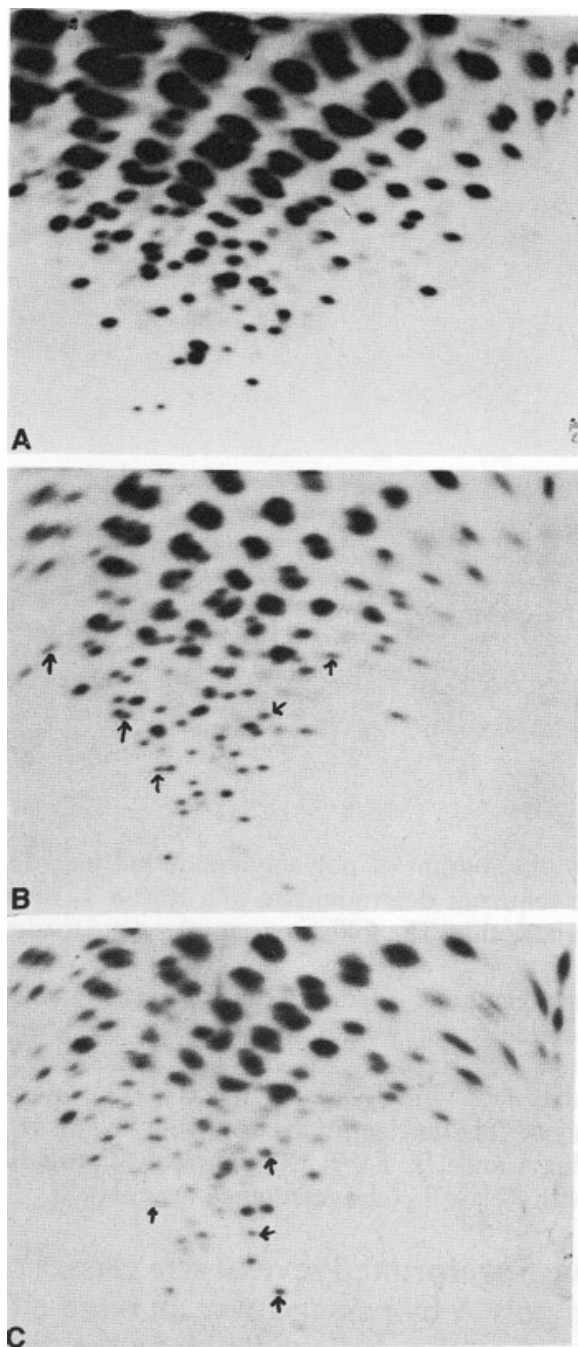

Fig. 4. RNase T_1 fingerprint of RNA from
A. Akv B. MCF 247 C. MB34

is implied. The oligonucleotides numbered in Fig. 5 have been identified by complete or partial sequence analysis.

The fingerprints of two polytropic MCF viruses (MCF247 and MB34) are presented in Fig. 4. Comparison of these fingerprints with that of the Akv virus shows that these viruses are structurally related.

The majority (60%) of the oligonucleotides are shared by all three isolates. However, there are several oligonucleotides that are unique to each polytropic isolate, and some of these are indicated by the arrows in Fig. 6. Moreover, a common set of oligonucleotides characteristic for the Akv virus is missing in each of the MCF viruses. These include oligonucleotides 8, 9, 13A, 17, 20, 31A, 46, 10, 11, 31, 56, 98A, 21. These are located near the 3' end of the gen-

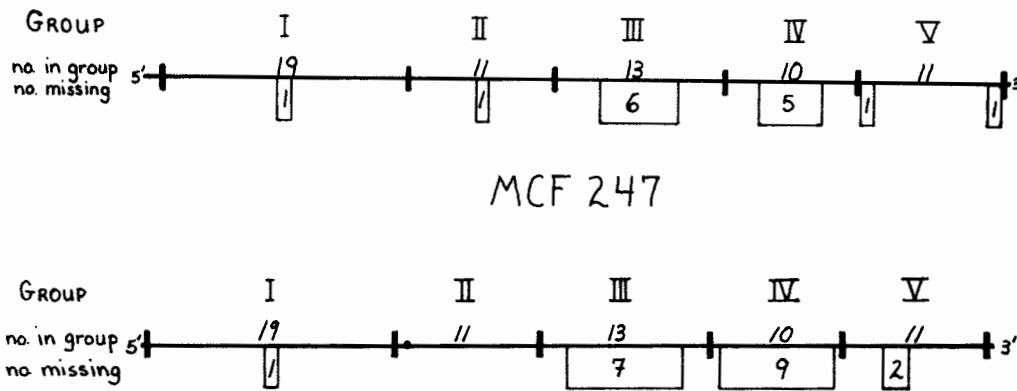

Fig. 5. Diagrams showing the location on the Akv virus genome of RNase T₁ resistant oligonucleotides absent in the two MCF viruses MCF247 and MB 34

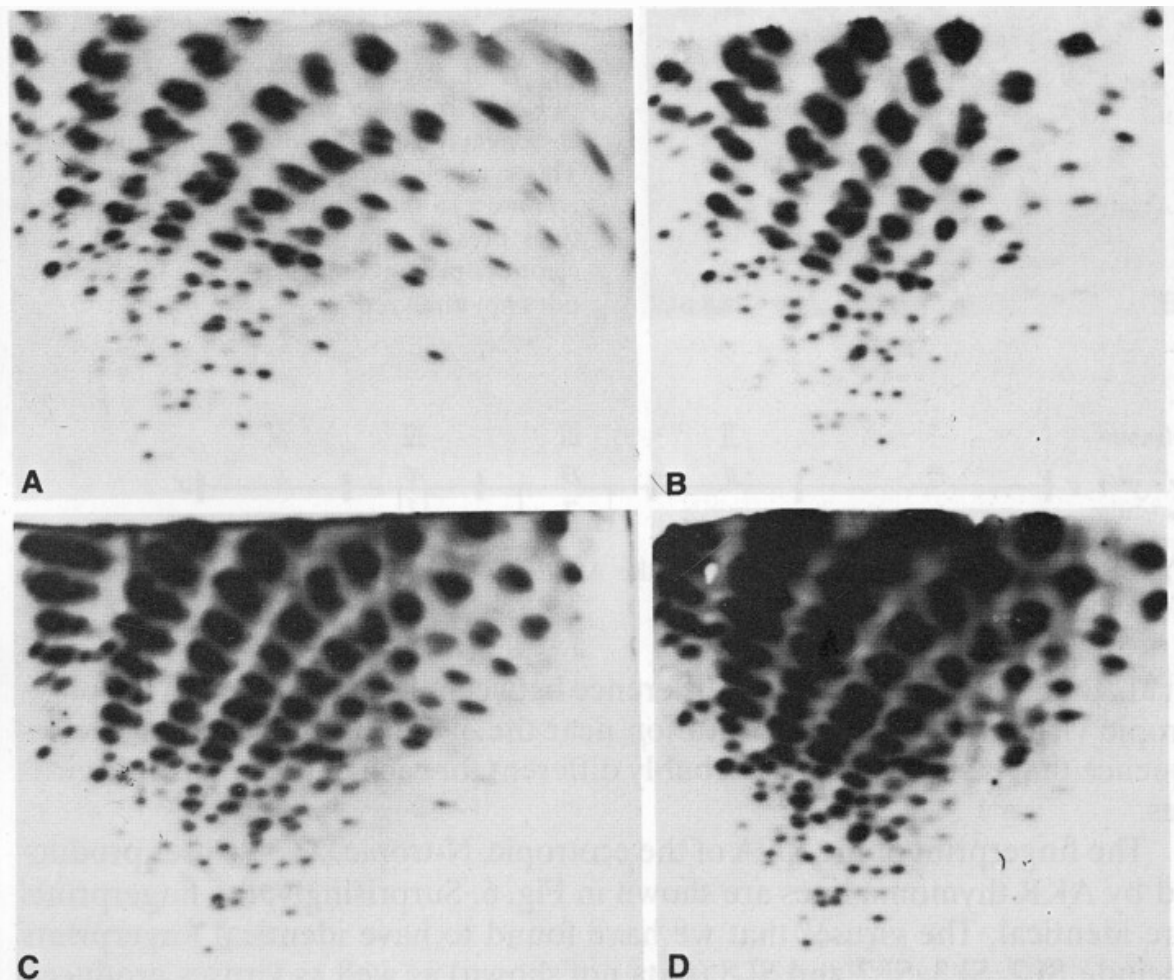

Fig. 6. RNase T₁ fingerprints of RNA from A. AKR SL2 B. AKR SL3 C. AKR SL7 D. AKR SL3 Cl 1

ome. Several other Akv oligonucleotides are missing from the fingerprint of each polytropic virus. Some but not all, are located near the 3' end of the genome. A schematic diagram that portrays the location along the genome of Akv oligonucleotides missing from the fingerprints of each polytropic virus is given in Fig. 5. This data is consistent with the observation of Rommelaere

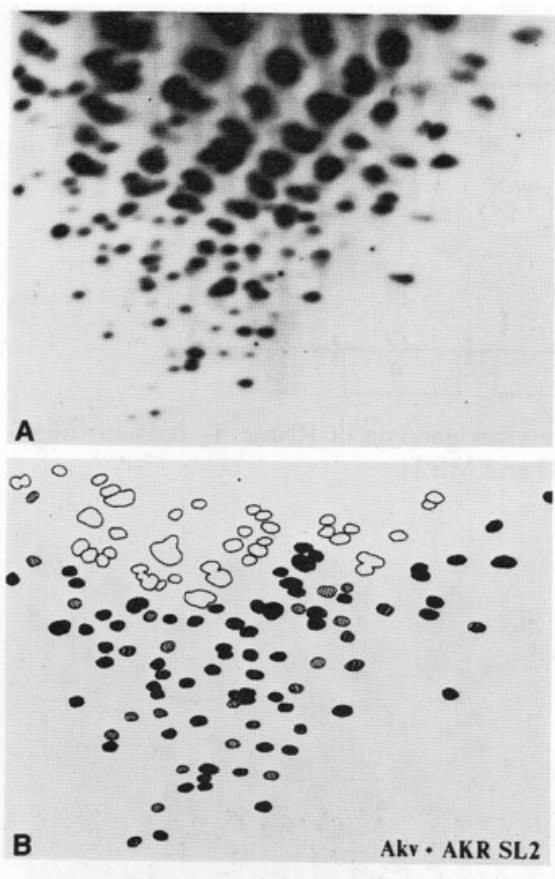

Fig. 7. *A.* RNase T₁ fingerprint of a mixture of RNAs from Akv virus and AKR SL2. *B.* Schematic diagram of the same fingerprint. The symbols used are: ● oligonucleotides common to the two viruses; ○ oligonucleotides present only in AKR SL2; ○ oligonucleotides present only in Akv; ○ oligonucleotides not analyzed

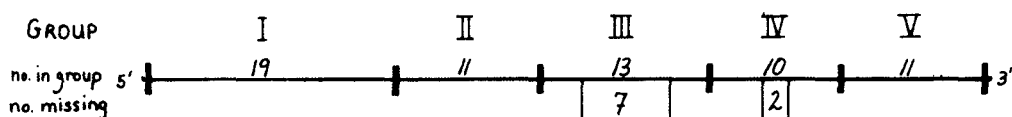

Fig. 8. Diagram showing the location on the Akv virus genome of RNase T₁ resistant oligonucleotides absent in AKR SL2

et al., that the major structural difference between the Akv virus and the polytropic virus consists of a substitution near the 3' end of the genome. The sequence that is substituted is probably different for each of the polytropic viruses.

The fingerprint of the RNA of the ecotropic, N-tropic, XC⁻ viruses produced by AKR thymoma lines are shown in Fig. 6. Surprisingly, the fingerprints are identical. The viruses that we have found to have identical fingerprints include SL2, SL3, SL7 and SL8 (data not shown) as well as viruses produced by cloned cells derived from SL2 (not shown) and SL3. We shall call this virus the AKR-SL (spontaneous lymphoma).

The AKR-SL virus is structurally related to the Akv virus. The majority of the oligonucleotides have the same electrophoretic mobility as shown in Fig. 7. However, oligonucleotides are unique to the AKR-SL virus. Moreover, a set of oligonucleotides present in the Akv fingerprint is missing from the AKR-SL fingerprint. The missing oligonucleotides are all located near the 3' end of the AKR genome as shown in Fig. 8. The set of oligonucleotides that is missing from the AKR-SL fingerprint includes some but not all of the oligo-

nucleotides located near the 3' of the AKR genome that are missing from all the polytropic viruses.

These studies identify structurally a new class of AKR virus. This virus, the ecotropic, N-tropic XC⁻ is the major species produced by AKR thymoma cells lines that have been established in culture. It probably differs from the Akv virus by a substitution in the 3' region of the genome. Some of the SL lines also produce detectable levels of either xenotropic or polytropic viruses. The amount of these viruses is not sufficient to appear in the fingerprints. However, passage of this virus on mink cells would favor enrichment of the virus for xenotropic and polytropic components.

The relationship of the AKR-SL virus to the induction of the disease is unclear. Whereas, SL2 and SL3 accelerate thymic disease in AKR mice, SL7 and SL8 do not (Nowinski and Hays, 1978). It is possible that either defective genomes or viruses produced at lower titers than the AKR-SL virus induce the disease.

We have begun a detailed characterization of the genome of a xenotropic virus AKR-6, a virus that was derived from a thymus of a two month old AKR mouse by Janet Hartley. The fingerprint of this virus (Fig. 9) is very different

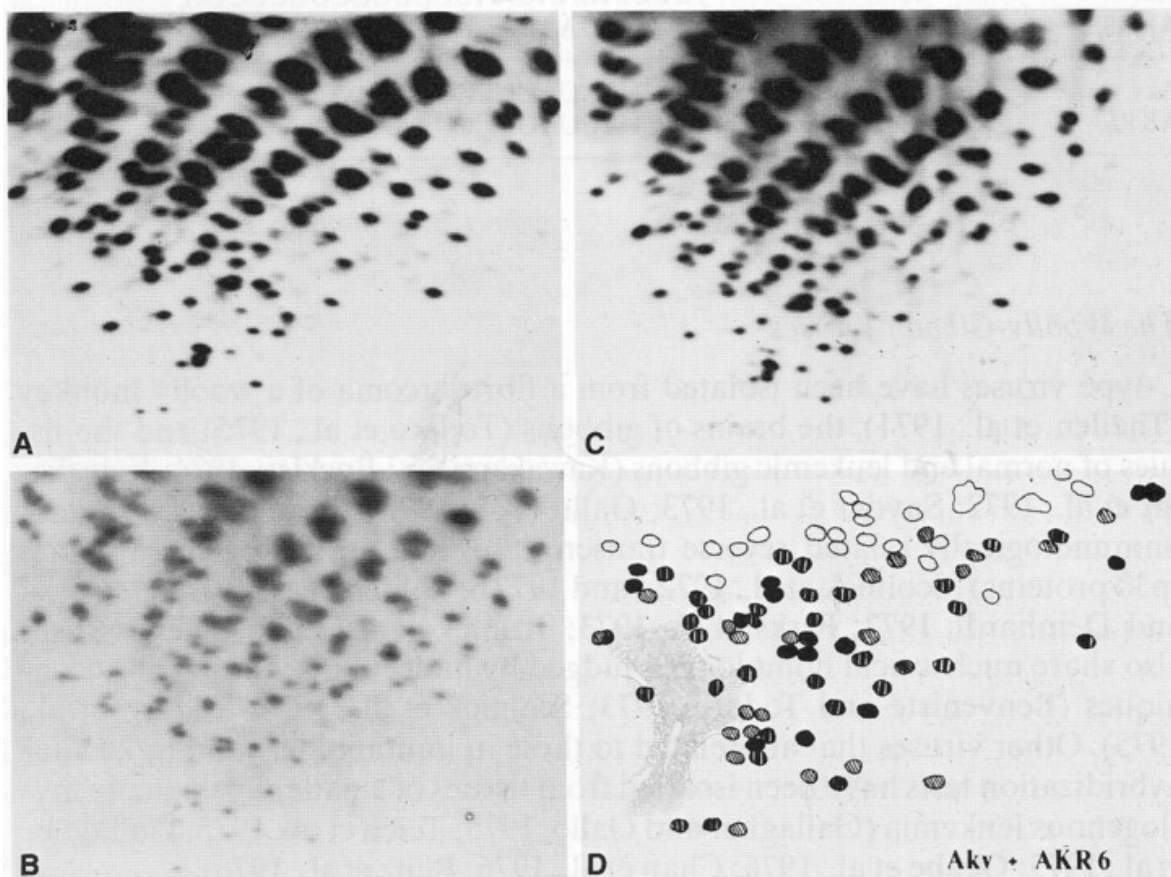

Fig. 9. Comparison of the RNase T₁ fingerprint of RNA from Akv virus (A) with the fingerprint of RNA from the xenotropic virus AKR6 (B) Panel C shows a RNase T₁ fingerprint of a mixture of RNA from the two viruses. (D) Schematic diagram of the picture shown in C. The symbols used are: ● oligonucleotides present in both viruses; ○ oligonucleotides present only in AKR6; ○ oligonucleotides only in Akv; ○ oligonucleotides not analyzed

from that of the Akv virus. Only a minority of the oligonucleotides have the same electrophoretic mobility. However, sequence analysis of some of the unique oligonucleotides shows that these viruses share many common sequences. The sequence of three oligonucleotides is identical in both viruses. Of ten large AKR-6 specific oligonucleotides that have been sequenced, five were found to be related by one or two base changes to oligonucleotides present in the Akv fingerprint (Table 2). It is noteworthy that a majority of the oligonucleotides present in the AKR-SL and AKR polytropic virus that are not present in the Akv virus are not derived from AKR-6, at least as judged by their electrophoretic mobility.

Table 2. Examples of related sequence in Akv and AKR6 RNA

Virus	Oligonucleotide No.	Nucleotide sequence
Akv AKR 6	1 101	UAUCUCCCAAACUCUCCCCCUCUCCAACG UCUCUCCCAAACUCUCCCCUCUCCAACG
Akv AKR6	15 108	AAAAUAAUAAUCCUCCUUCUCUG AAAAUAAUAACCCUCCUUCUCUG
Akv AKR6	18 113	AUCUACUAUCCUAAAAG AUCUACUAUUUCUAAAAG

The Woolly-Gibbon Viruses

C-type viruses have been isolated from a fibrosarcoma of a woolly monkey (Theilen et al., 1971), the brains of gibbons (Todaro et al., 1975) and the tissues of normal and leukemic gibbons (Kawakami and Buckley, 1974; Kawakami et al., 1972; Snyder et al., 1973; Gallo et al., 1978). These viruses contain immunologically related reverse transcriptases and group-specific antigens (p30 proteins) (Scolnick et al., 1972 a and 1972 b; Gilden et al., 1974; Hoekstra and Deinhardt, 1973; Parks et al., 1973; Tronick et al., 1975). These viruses also share nucleic acid homology as judged by molecular hybridization techniques (Benveniste and Todaro, 1973; Scolnick et al., 1974; Todaro et al., 1975). Other viruses that are related to these in immunologic and molecular hybridization tests have been isolated from tissues of a patient with acute myelogenous leukemia (Gallagher and Gallo, 1975; Teich et al., 1975; Gallagher et al., 1975; Okabe et al., 1976; Chan et al., 1976; Reitz et al., 1976).

To elucidate the structural relationships among these viruses, we have fingerprinted the genomes of the woolly monkey virus (SSAV or WLV) and several independently isolated gibbon ape viruses (GaLV) as well as virus isolated from the cultured cells of a patient with acute myelogenous leukemia (HL23V).

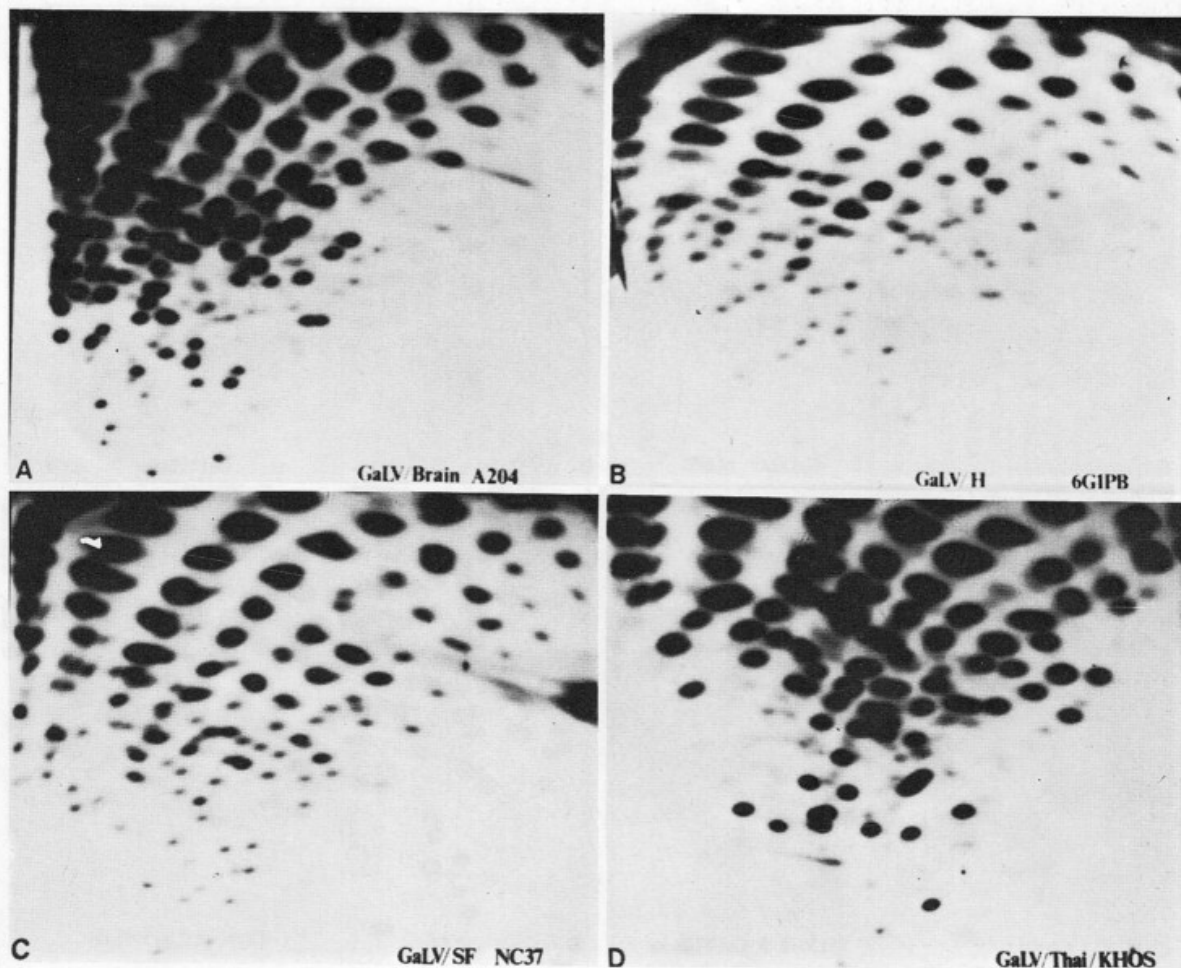

Fig. 10. RNase T_1 fingerprints of four isolates of gibbon ape viruses. A. GaLV_{Brain}, isolated by cocultivation of normal gibbon brain tissue with human rhabdomyosarcoma cells (A204) (Todaro et al., 1975). Virus was a gift from G. Todaro. B. GaLV_H, isolated from the blood of a gibbon with acute lymphatic leukemia (6 GIPB) (Gallo et al., 1978). Virus was obtained from R. Gallagher. C. GaLV_{SF}, isolated from a lymphosarcoma and grown in human lymphoblastoid cells (NC37) (Kawakami et al., 1972; Snyder et al., 1973). D. GaLV_{Thai}, isolated from a gibbon with granulocytic leukemia and grown in human osteogenic sarcoma cells transformed by Kirsten sarcoma virus (KHOS) (Kawakami and Buckley, 1974). Both GaLV_{SF} and GaLV_{Thai} were given to us by M. Reitz

The RNase T_1 fingerprints of the genomes of four independent isolates of gibbon virus and of SSAV are shown in Figs. 10 and 13. The genomes of two of the gibbon viruses, GaLV_H and GaLV_{Brain}, are closely related to one another as judged by the similarities of their RNase T_1 oligonucleotide patterns (Fig. 11). By studying the oligonucleotides which comigrated on polyacrylamide gels when RNase T_1 digests of GaLV_H and GaLV_{Brain} RNAs were mixed, we estimate that a minimum of 12% of the genomes are identical. The sequence of more than a quarter of these oligonucleotides was studied. In most cases, oligonucleotides which comigrated had the same sequence. The two oligonucleotides whose sequences were not identical appeared to be a mixture of more than one RNase T_1 product. In contrast, only 2.5% of the genome of each virus is distinct. Assuming that the oligonucleotides are randomly positioned as much as 70% of the genomes could be identical.

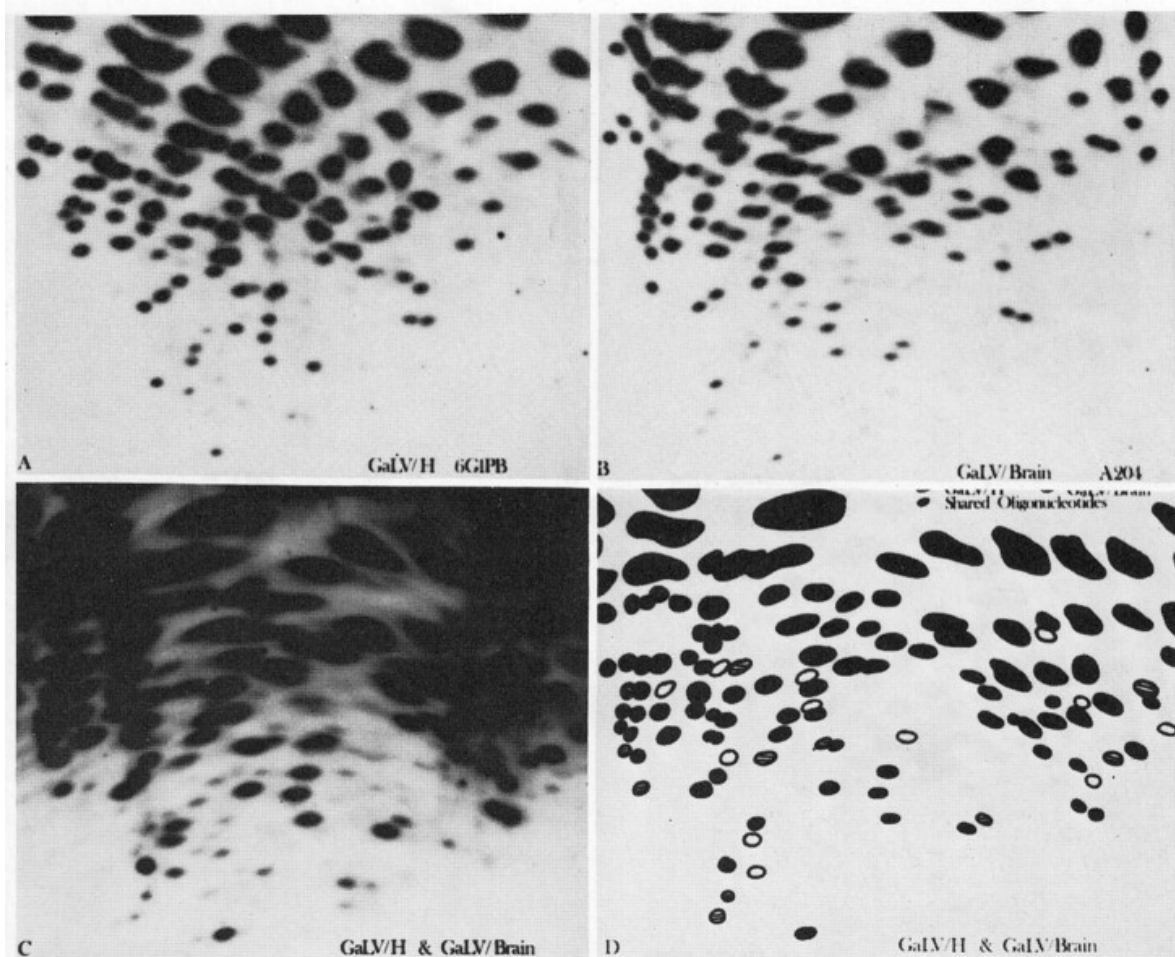

Fig. 11. Comparison of the genomes of two gibbon ape viruses, GaLV_H and GaLV_{Brain}. The RNase T₁ fingerprints of A. GaLV_H, B. GaLV_{Brain} and C. a mixture of GaLV_H and GaLV_{Brain} are shown. D. A schematic illustration of the mixture shown in panel C. The oligonucleotides shared by these two viruses as well as those unique to one or the other of the viruses are diagrammed. The assignment of two oligonucleotides as a shared sequence was also confirmed for twenty of the large oligonucleotides by the position of adenosine residues within each oligonucleotide by RNase U₂ digestion

The other gibbon viruses and SSAV show a smaller degree of similarity by fingerprint analysis of their genomes. For example, fewer of the longer characteristic oligonucleotides of SSAV RNA and GaLV_{SF} RNA have the same electrophoretic mobility (Fig. 12). The fingerprints of the viruses shown in Figs. 10, 11 and 12 demonstrate that this method provides a means of identifying viruses and of distinguishing between closely related isolates of primate viruses.

We have also fingerprinted the genomes of SSAV viruses with different passage histories (Fig. 13). The RNase T₁ fingerprints of these viral RNA isolates are very similar but not identical to one another. WLV RNA has only two oligonucleotides not present in the SSV-1 genome whereas SSV-1 RNA has four oligonucleotides not found in the WLV genome. Because SSAV has only been isolated from a single woolly monkey, the nucleotide sequence of the viral RNA changed during passage.

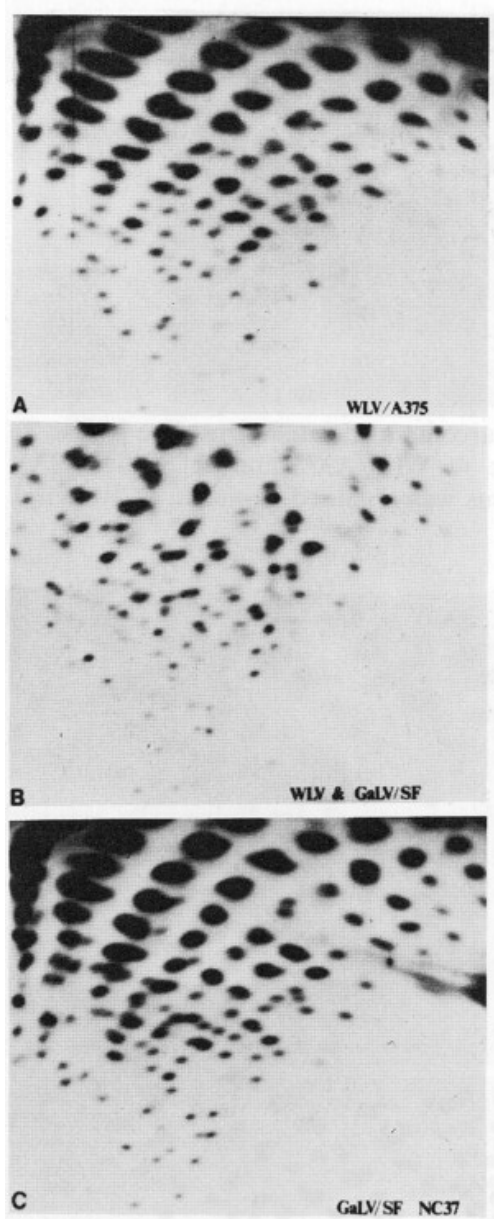

Fig. 12. Comparison of the genomes of Simian sarcoma associated virus, WLV, and gibbon ape virus, GaLV_{SF}. The RNase T₁ fingerprints of A. WLV/A375, isolated from a fibrosarcoma of a woolly monkey (Theilen et al., 1971) and grown in human cells given to us by S. Aaronson; B. a mixture of WLV/A375 and GaLV_{SF} and C. GaLV_{SF} are shown

The RNase T₁ fingerprints of the genomes of viruses released by cultivation of leukemic tissues from a patient with acute myelogenous leukemia (HL23V) are presented in Figs. 14 and 15. These viral isolates are closely related to SSAV. The majority of the oligonucleotides of HL23V RNA have the same electrophoretic mobility as those of WLV RNA (Fig. 14C). Studying the oligonucleotides which are present only once in the genome and shared by WLV RNA and HL23V RNA, there appears to be a minimum of 11% of the genomes which are identical. We determined the position of the adenosine residues in one-half of the oligonucleotides which comigrated on polyacrylamide gels when digests of the two RNAs are mixed. In all cases, oligonucleotides which comigrated had the same sequence. However, a minority of the genome is unique to the HL23V isolate (3%) or to WLV (1.5%). Assuming that these oligonucleotides are present throughout the genome, we estimate that as much as 75% of these viral RNAs are identical.

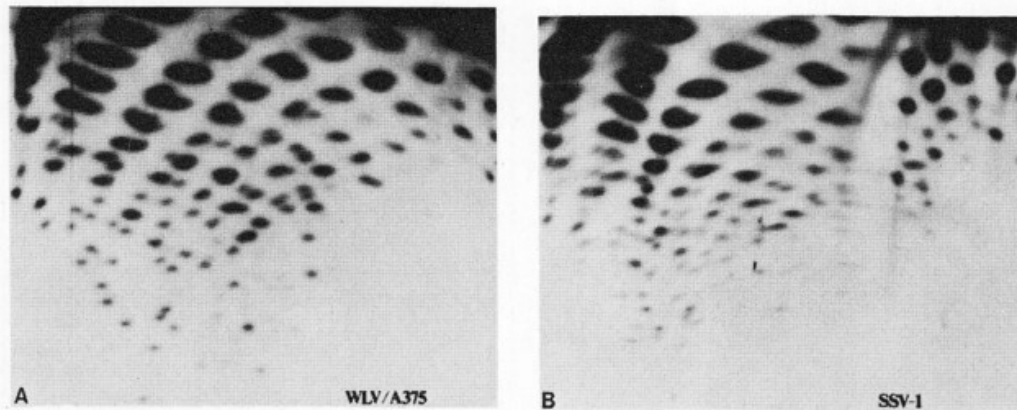

Fig. 13. Effect of different passage histories on Simian sarcoma associated virus. The RNase T₁ fingerprints of two SSAV virus isolates are compared: A. WLVA375 and B. SSV-1, SSAV grown in human lymphoblastoid cells (NC37). This virus was obtained from the FCRC Viral Resources Laboratory

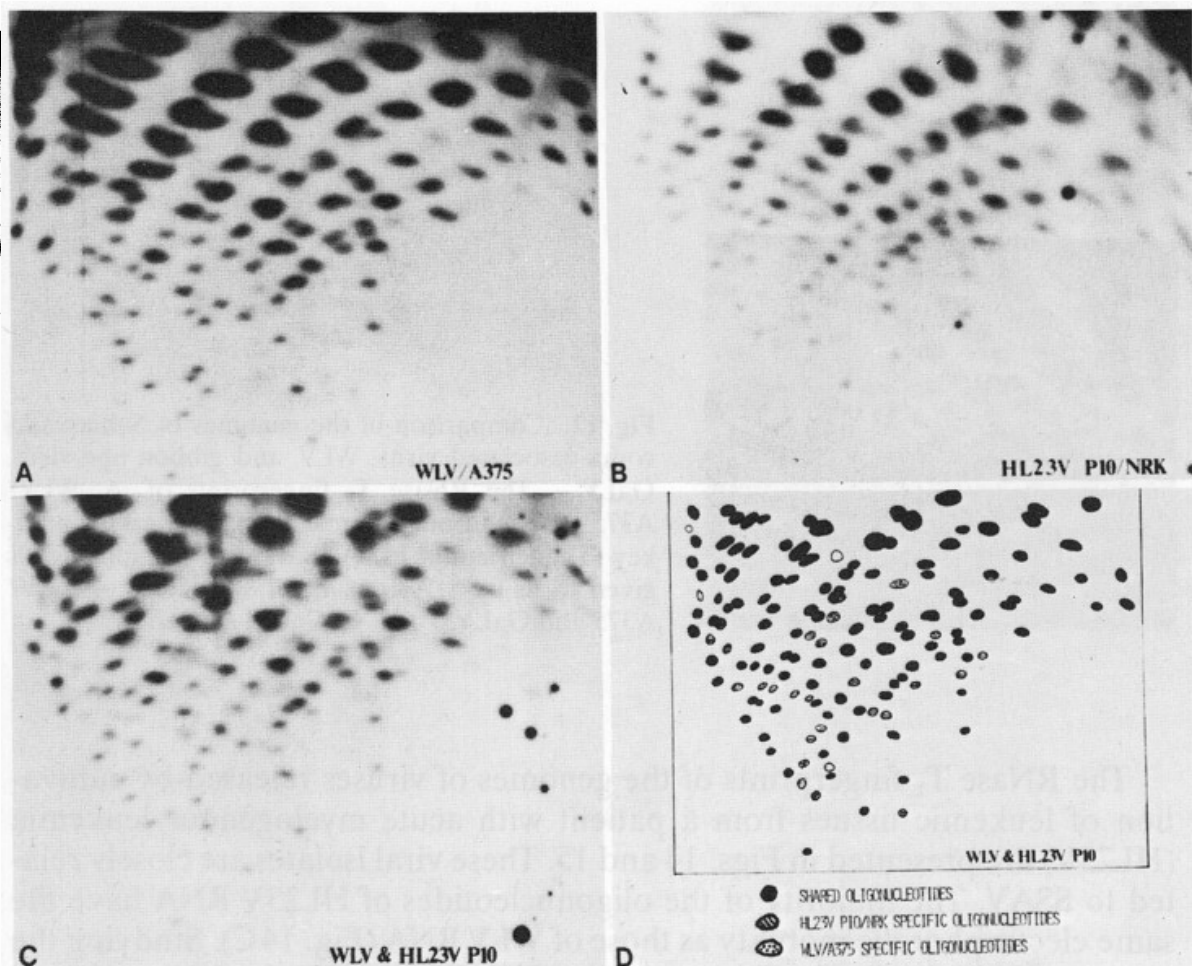

Fig. 14. Comparison of the genomes of Simian sarcoma associated virus, WLV, and a virus, HL23V, released by cultured human myeloid leukemia cells. The RNase T₁ fingerprints of A. WLVA375; B. HL23V p10/NRK, isolated by cultivation of leukocytes from the first peripheral blood sample that had been passaged ten times before the culture fluid was used to infect normal rat kidney fibroblasts (Teich et al., 1975; Gallagher and Gallo, 1975); and C. a mixture of WLVA375 and HL23V p10/NRK. D. a schematic illustration of the mixture shown in panel C. The oligonucleotides shared by these two viruses as well as those unique to one or the other of the viruses are diagrammed. The assignment of two oligonucleotides as a shared sequence was also confirmed for many of the large oligonucleotides by the position of adenosine residues within each oligonucleotide by RNase U₂ digestion. HL23V p10/NRK RNA was obtained from M. Reitz

when injected into newborn kittens (Jarrett et al., 1973; Essex, 1975). Moreover, epidemiological evidence demonstrates that these viruses are the causative agents of feline leukemia in domestic cat populations (Hardy et al., 1973; Cotter et al., 1975; Hardy et al., 1976; Essex et al., 1977).

The feline viruses have been shown to be structurally related by tests of molecular hybridization (Levin et al., 1976). However, they are not identical. These viruses have been divided into three groups, FeLV A, B, and C, on the basis of neutralization and interference tests (Sarma and Log, 1973). These viruses also differ in their host range (Jarrett et al., 1973; Sarma et al., 1975).

To determine the degree of structural similarity of these viruses at the level of nucleic acid sequence, fingerprint analysis of viruses of the three subgroups was done. The viruses analyzed include the cloned isolates FeLV A/Glasgow 1, FeLV B/Sarma (ST-FeSV), and FeLV C/Sarma (FL74) that were grown in feline embryo fibroblasts, and FeLV A/Rickard that was produced by an established lymphoid tumor line F422 (Rickard et al., 1969).

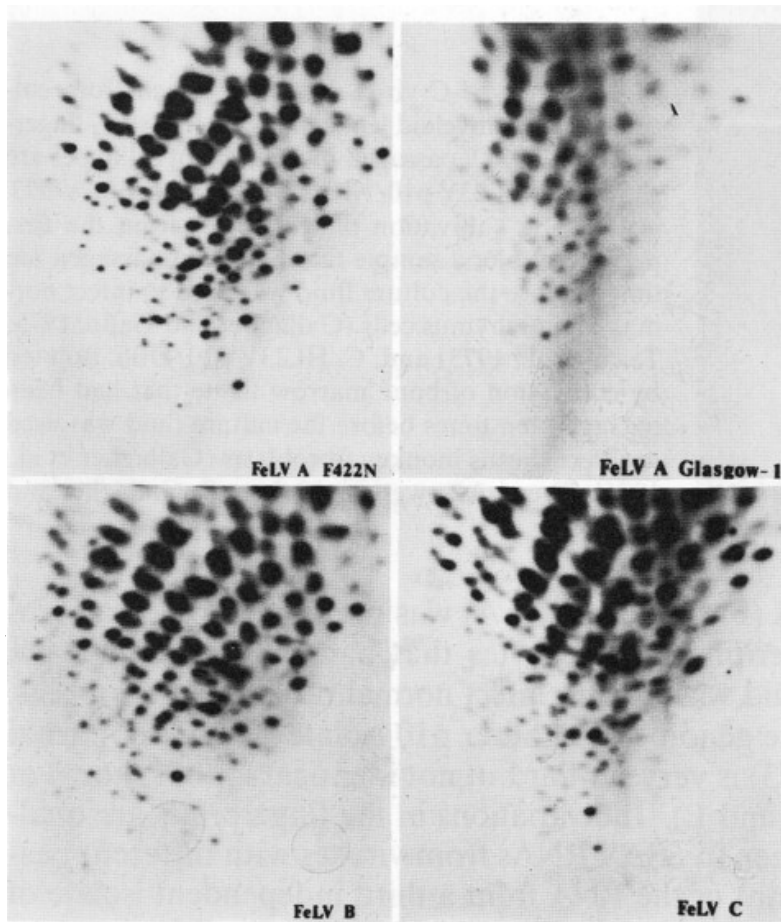

Fig. 16. RNase T_1 fingerprints of the subgroups of FeLV. *Upper left:* FeLV A/Rickard isolated and grown in F422 cells, a spontaneous lymphoid cell line, provided by M. Essex. *Upper right:* FeLV A/Glasgow 1 isolated from a cat with alimentary lymphosarcoma and grown in feline embryo fibroblasts. *Lower left:* FeLV B/Sarma (ST-FeSV), the purified subgroup B helper virus from a stock of Snyder-Theilen FeSV, grown in feline embryo fibroblasts. *Lower right:* FeLV C/Sarma (FL74) purified from a mixture of subgroups A, B, and C isolated from a spontaneous lymphoid cell line, FL 74, and grown in feline embryo fibroblasts. FeLV A/Glasgow 1, FeLV B and FeLV C were provided by O. Jarrett

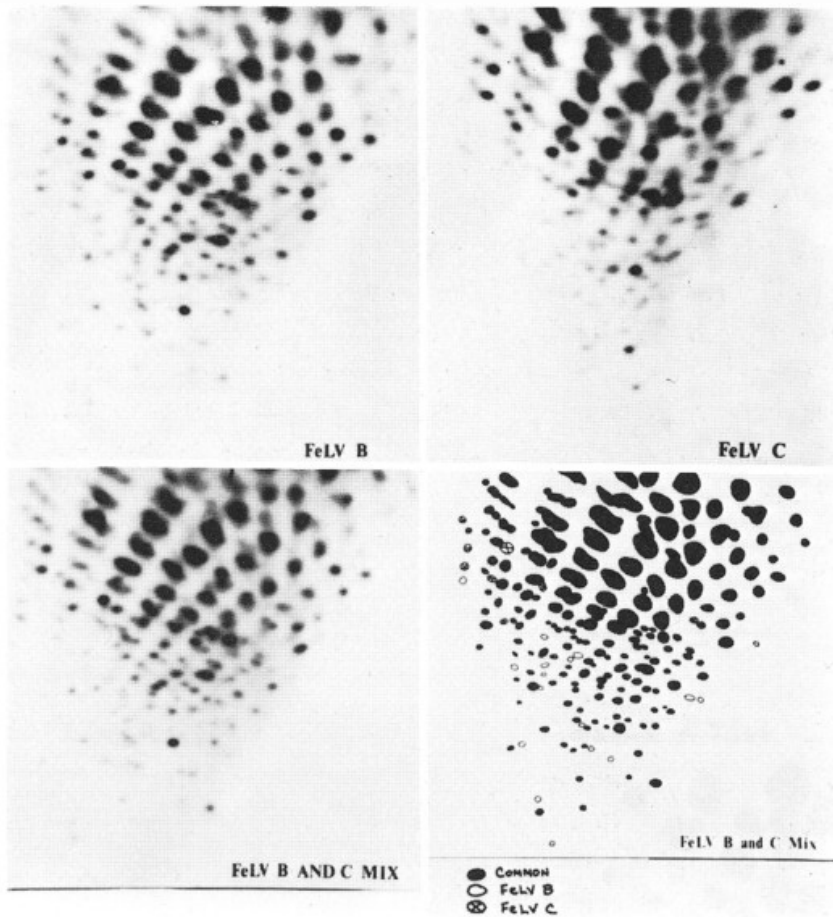

Fig. 17. Comparison of the genomes of FeLV: RNase T_1 fingerprints of isolates from subgroups Band C. *Upper left:* FeLV B/Sarma (ST-FeSV). *Upper right:* FeLV C/Sarma (FL74). *Lower left:* Mixture of FeLV B and FeLV C. *Lower right:* Schematic drawing of a mixture of subgroups B and C

The fingerprints of these viruses are presented in Fig. 16. To determine the degree of structural similarity, RNase T_1 oligonucleotides from the subgroups were mixed together and the resulting fingerprints are shown in Fig. 17. Experiments done but not pictured include mixes of FeLV A/Rickard and FeLV A/Glasgow 1, FeLV A/Rickard and FeLV B/Sarma (ST-FeSV), and FeLV A/Rickard and FeLV C/Sarma (FL74).

These experiments demonstrated that the feline leukemia viruses are structurally closely related. Over half the unique oligonucleotides of each isolate are found in all the isolates studied as judged by their electrophoretic mobility in the mixing experiments. This set of "common" FeLV oligonucleotides is diagrammed in Fig. 18. However, a set of oligonucleotides unique to each isolate was also observed. The fingerprints of the two subgroup A viruses studied were not identical.

The similarity in the fingerprints of the feline leukemia viruses suggests that approximately half of the genome is identical.

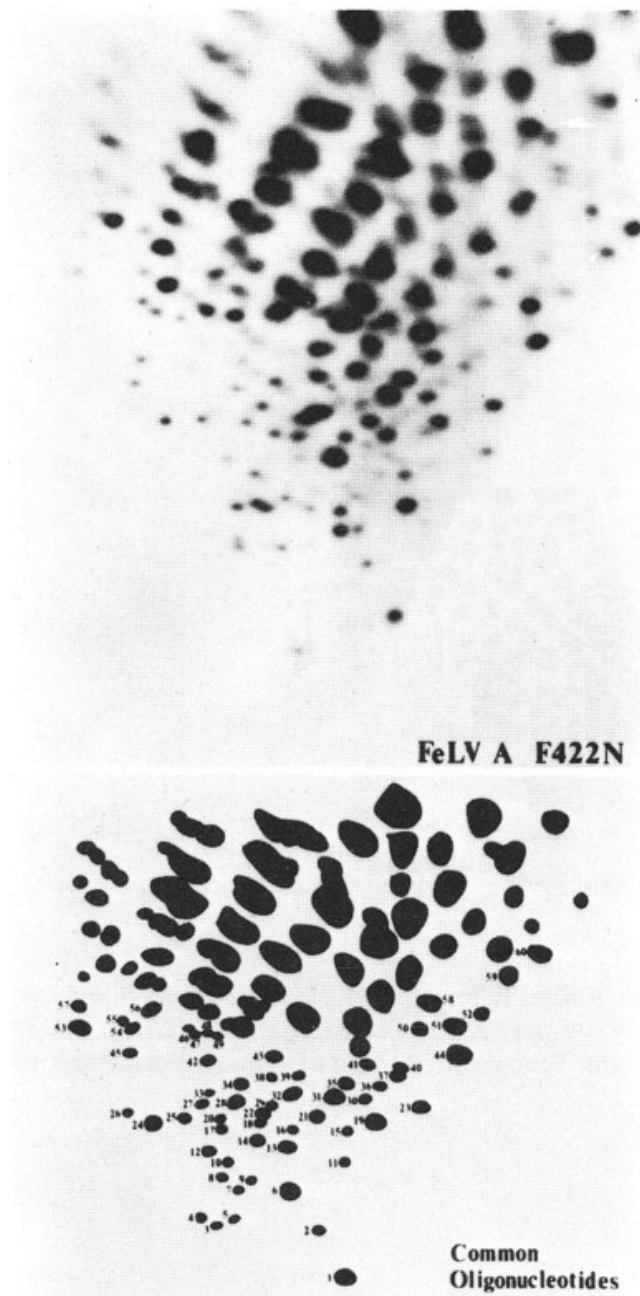
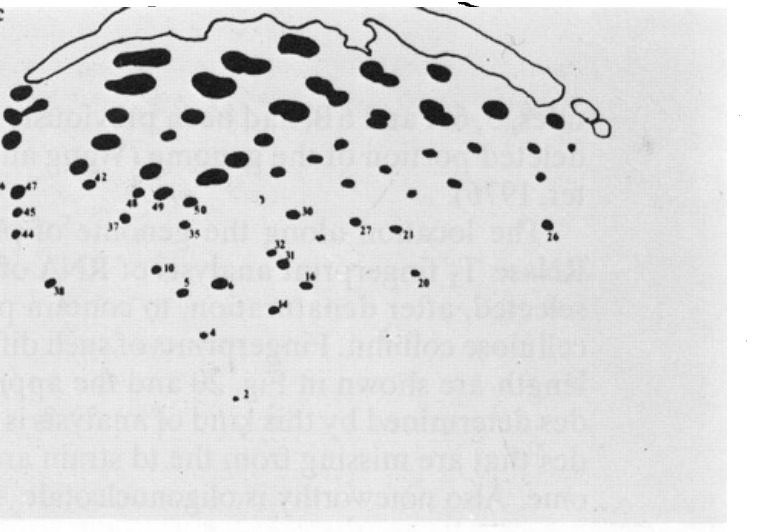
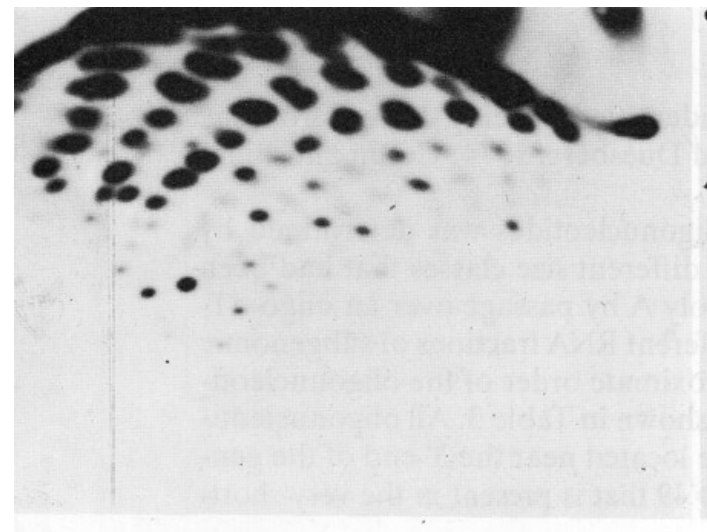
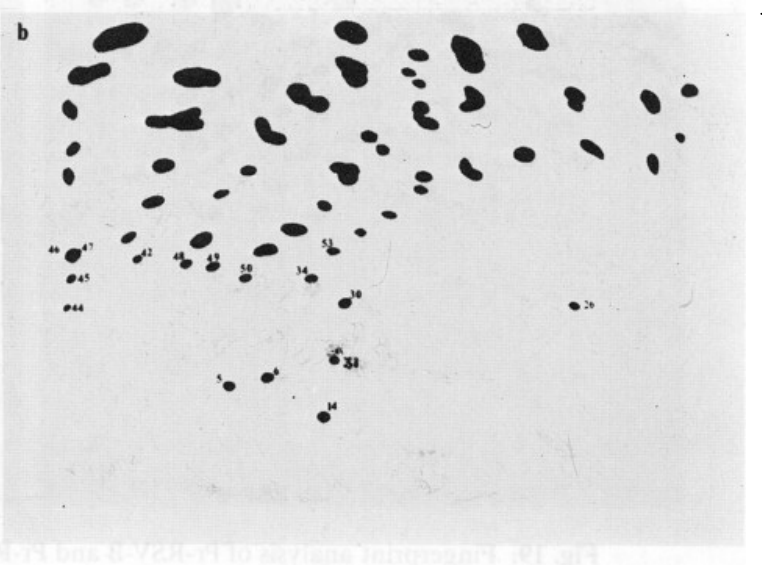
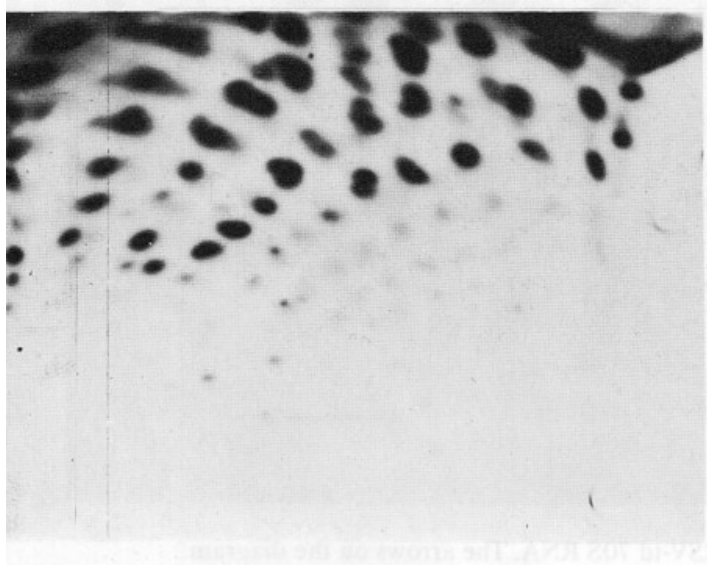
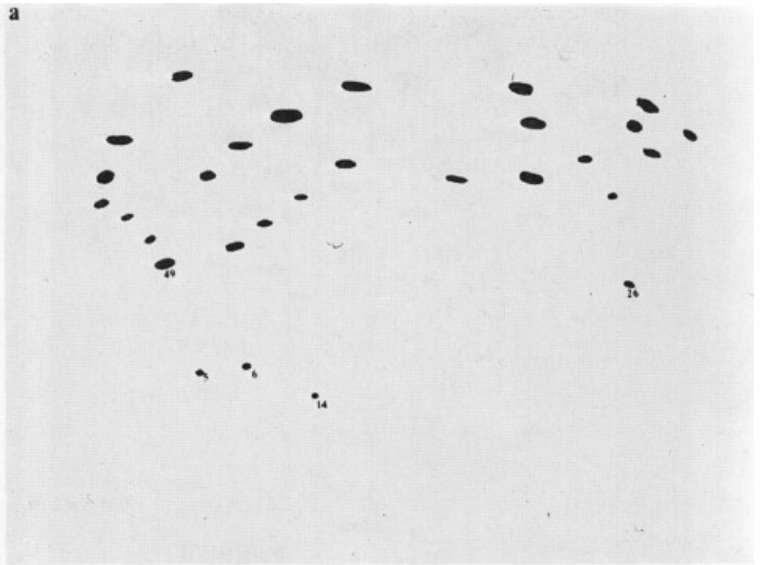
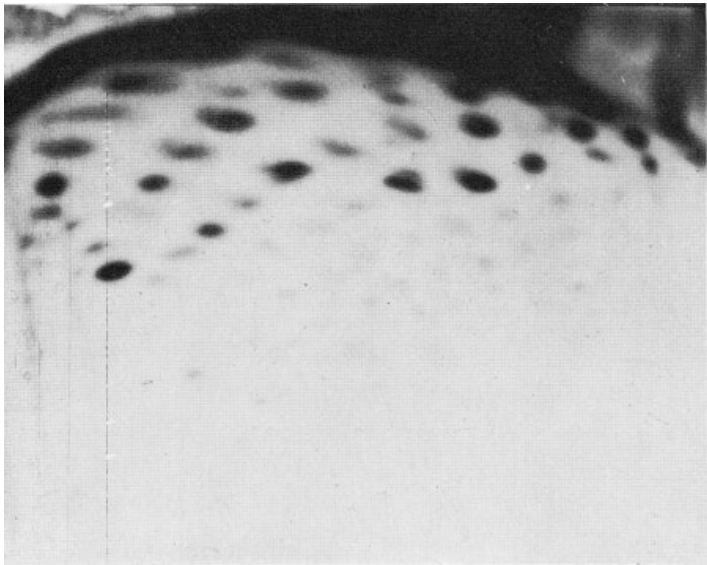

Fig. 18. RNase T_1 oligonucleotides shared between FeLV A/Rickard, FeLV A/Glasgow 1, FeLV B/Sarma (ST-FeSV), and FeLV C/Sarma (FL74). *Top:* Representative fingerprint of FeLV, FeLV A/Rickard. *Bottom:* Schematic drawing of the "common" oligonucleotides

Rous Sarcoma Virus

We have applied the improved fingerprinting technique to Rous sarcoma virus Prague B in order to obtain more detailed information regarding the sequences of the sarcoma gene. A variant of this strain of virus has been isolated that lacks the capacity to transform fibroblasts in culture (Coffin and Billeter, 1976). This transformation defective strain is deleted for a portion of the genome, about 1500 nucleotides near the 3' end of the genome (Junghans et al., 1977).

RNase T_1 fingerprints of the non-defective (nd) and transformation defective (td) strains of the virus are shown in Fig. 19. The arrows indicate those oligonucleotides that are missing from the td strain. The missing oligonucleotide include numbers: 5, 6 (A + B), 48, 42, 45 and 44. Three of the oligonucleo-



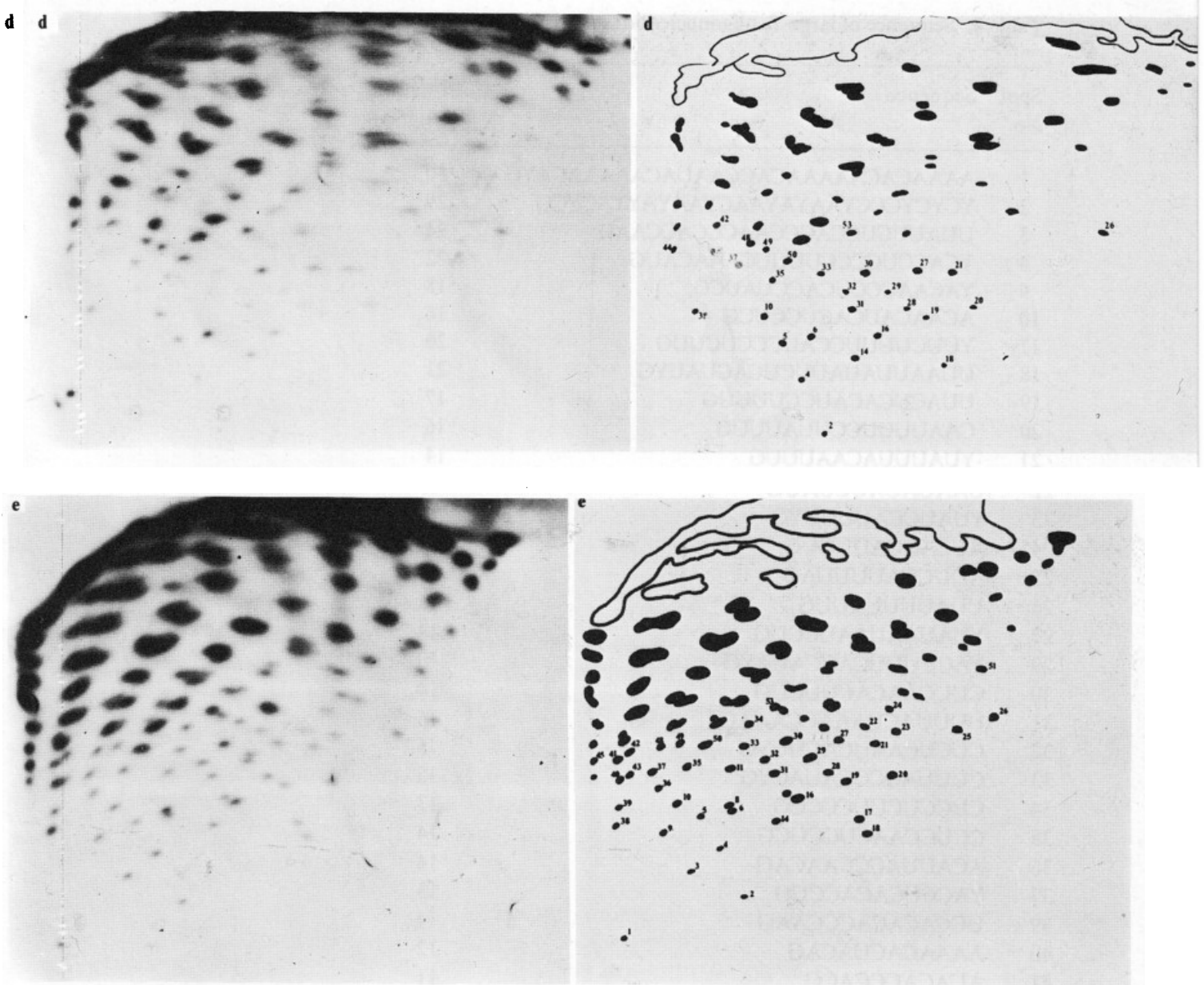

Fig. 20. Mapping of RNase T₁ oligonucleotides derived from different sizes of Pr-RSV-B RNA fragments. RNA fragments obtained by heating 35S poly-A-containing RNA, were separated by sedimentation in sucrose density gradient, followed by poly-A-selection on oligo-T-cellulose column. The size of RNA fragments increase in order of a, b, c, d and e. Panel E shows the fingerprint of 35S RNA

Table 3. Order of large T₁ Oligonucleotides on Pr-B RSV RNA

5' end (11, 8, 16B, 15, 24, 23, 25, 3, 17, 39) (18, 1, 36, 22, 41, 20, 40, 43, 9, 33, 29, 28, 12, 9) (50B, 4, 35, 16A, 2, 32, 20, 10, 37, 38, 27) (21, 53, 50A, 30, 31, 48, 42, 47, 46, 45, 44) (26, 14, 6, 5, 49)-poly A

^a Interferred by visual examination of the fingerprints of fractionated Pr-B RNA, as described in Fig. 20. The order of oligonucleotides within parentheses is undetermined

Table 4. Sequence of large T₁ oligonucleotides from Pr-B 70S RNA

Spot No.	Sequence	Chain length
1	AAAACACAAAAACACCAAUACAAAAACAYG	30
2	YCYCYCCCYAAYAYAACYAAYAYYACYCG	29
3	UUAUUCUCCACCCAACCCACCAAG	24
4	YCACCUCUUUUUCAAAACAUG	22
9	YACAACCCUCACCUAUCG	18
10	ACAACAUCACUCCUCG	16
17	YUUCUUUCCAUCCCUUUG	20
18	UUAUUUAUUAUCUCACUAUYG	21
19	UUACUCACAUCUUUUG	17
20	CAUUUUCCUUUUUUG	16
21	YUAUUUACAAUUUG	14
22	UAAUAUAUCUAUG	13
23	YUAUCCAUUUUYG	13
24	AUCACUAUUUUG	12
25	AUUUCAUUUUG	12
26	UUAUUUUUUUG	11
27	YUAUAAUAAUCCUG	14
29	YACUUUUCACCAUAYG	15
30	CUUCAACACUUCUG	14
31	UUUUACUAAACCAAAG	16
32	CUCUCAAUACUUYG	15
33	CUUUACCCCAUACYG	15
34	CUCCUCUUCUCCG	13
35	CCUCCAACUCCUCG	14
36	ACAUUACCCAACAG	14
37	YACCUCACACCUUG	13
39	UCCACACACCCAAG	14
40	AAAACACUACAG	12
41	AUACACCCACG	11
42	ACAACAAUACG	11
43	AYAUAAAAACAG	12
44	CACCCACACG	11
45	YAAACCACAG	10
46	CAACACCAG	9
47	AACACCAAG	9
48	AUACAUCCUCCAG	12
49	AUACAAUAAACG	12
52	AUAUUUYG	8
53	AUAAUAUACAUG	12

est poly A containing RNA fragment. This oligonucleotide is probably the one identified by Wang et al. (1975) as the C or constant oligonucleotide, present in both RSVtd and nd strains. This oligonucleotide is located between the td deletion and the 3' end of the genome.

To further characterize the structure of the RSV genome the sequence of most of the unique oligonucleotides was determined as described above. The sequences are presented in Table 4. The table includes the sequence of oligonucleotides derived from the region deleted in the td strain.

The spots numbered 6, 16, 38 and 50 are not sequenced because they contain a mixture of oligonucleotides.

Discussion

The improved techniques of oligonucleotide fingerprinting using small unlabelled RNA have permitted us to extend the range of problems that can be approached using this method. Viruses that cannot be efficiently labelled in cell culture, either because of their low titer or because of the cell type (for example the lymphoid lines) can be studied by this method. Moreover, sequence determination of oligonucleotides permits very detailed comparative analysis of viral genomes. An example of the utility of this approach is the unexpected similarity in sequence of the unique oligonucleotides of Akv virus and the AKR-6.

This approach is not limited to the C-type viruses. The method is suitable for the study on any high molecular RNA species. We have, in collaboration with others, successfully applied the method to problems of human and avian influenza viruses, measles virus, vesicular stomatitis virus and silk worm fibroin message.

Acknowledgements

We thank R. Nowinski and E. Hays for making the AKR spontaneous lymphoma lines available to us for this study; Janet Hartley and Wallace Rowe for the AKR-247, MB-34 and Akv-1 and Akv-2 strains; S. A. Aaronson, R. Gallo, G. Todaro, M. Reitz, R. Gallagher, R. Smith for providing purified woolly-gibbon virions and viral RNA; and O. Jarrett and M. Essex for providing the feline viruses. This work was supported by grants to W.H. from National Cancer Institute (#R01 CA1934 and #CP 71057) and American Cancer Society (3920590). W.H. is a recipient of an ACS Faculty Research Award. F.S.P. is a fellow of the Leukemia Society of America, Inc. and of the Danish National Science Research Council. B.G.S. is a recipient of a National Institutes of Health Fellowship (1 F32 CA05926-01) from the National Cancer Institute. Z.F.R. is supported by a National Institutes of Health Grant (AID0014). We thank Meredith Simon and Lynn Mastalir for expert technical help.

References

- Benveniste, R. E., Todaro, G. J.: *Proc. Natl. Acad. Sci. USA* **70**, 3316–3320 (1973)
Chan, E., Peters, W. P., Sweet, R. W., Ohno, T., Kufe, D. W., Spiegelman, S., Gallo, R. C., Gallagher, R. C.: *Nature* **260**, 266–268 (1976)
Coffin, J. M., Billiter, M. A.: *J. Mol. Biol.* **100**, 293–318 (1976)
Cotter, S. M., Hardy, W. D., Jr., Essex, A.: *JAVMA* **166**, 447–455 (1975)
Donis-Keller, H., Maxam, A. M., Gilbert, W.: *Nucl. Acids Res.* **4**, 2527–2538 (1977)
Elder, J., Jensen, F., Lerner, R., Hartley, J. W., Rowe, W. P.: *Proc. Natl. Acad. Sci. USA* **74**, 4676–4680 (1977)
Essex, M.: *Adv. Cancer Res.* **21**, 175–248 (1975)

- Essex, M., Cotter, S. N., Sliski, A. H., Hardy, W. D., Jr., Stephenson, J. R., Aaronson, S., Jarrett, O.: *Internat. J. Cancer* **19**, 90–96 (1977)
- Gallagher, R. E., Gallo, R. C.: *Science* **187**, 350–353 (1975)
- Gallagher, R. E., Salahuddin, S. Z., Hall, W. T., McCredie, K. B., Gallo, R. A.: *Proc. Natl. Acad. Sci. USA* **72**, 4137–4141 (1975)
- Gallo, R. C., Gallagher, R. E., Wong-Stall, F. W., Aoki, T., Markham, P. D., Schettters, H., Ruscetti, F., Valerio, M., Walling, M., O'Keefe, R. T., Saxinger, W. C., Smith, R. G., Gillespie, D. H., Reitz, M. S.: *Virology* **84**, 359–373 (1978)
- Gilden, R. V., Toni, R., Hanson, M., Bova, D., Charman, H. P., Oroszlan, S. J.: *Immunol.* **112**, 1250 to 1257 (1974)
- Hardy, W. D., Jr., Old, L. J., Hess, P. W., Essex, M., Cotter, S. M.: *Nature* **244**, 266–269 (1973)
- Hardy, W. D., Jr., Hess, P. W., MacEwen, E. G., McClelland, A. J., Zuckerman, E. E., Essex, M., Cotter, S. M., Jarrett, O.: *Cancer Res.* **36**, 582–588 (1976)
- Hartley, J. W., Wolford, N. K., Old, L. J., Rowe, W. P.: *Proc. Natl. Acad. Sci. USA* **74**, 780–792 (1977)
- Hoekstra, J., Dienhardt, F.: *Intervirology* **2**, 222–230 (1973)
- Jarrett, O., Laird, H. M., Hay, D. J.: *Gen. Virol.* **20**, 169–175 (1973)
- Jarrett, W. F., Crawford, E. M., Martin, W. B., Davie, F.: *Nature (London)* **202**, 567–569 (1964)
- Jarrett, W. F., Jarrett, O., Mackey, L., Laird, H. M., Hardy, W. D., Jr., Essex, M.: *JNCI* **51**, 833–841 (1973)
- Junghans, R. P., Hu, S., Davidson, N.: *Proc. Natl. Acad. Sci. USA* **74**, 477–481 (1977)
- Kawakami, T., Buckley, P. M.: *Transplant Proc.* **6**, 193–196 (1974)
- Kawakami, T. G., Huff, S. D., Bickley, P. M., Dungworth, D. C., Snyder, J. P., Gilden, R. V.: *Nature New Biol.* **235**, 170–171 (1972)
- Kawashima, K., Ikeda, H., Hartley, J. W., Stochert, E., Rose, W. P., Old, L. J.: *Proc. Natl. Acad. Sci. USA* **73**, 4680–4684 (1976)
- Levin, R., Ruscetti, S. K., Parks, W. P., Scolnick, E. M.: *Int. J. Cancer* **18**, 661–671 (1976)
- Nowinski, R. C., Hays, E.: *J. Virol.* **27**, 13–18 (1978)
- Nowinski, R. C., Hays, E. F., Doyle, T., Linkhart, S., Medeiros, E., Pickering, R.: *J. Virol.* **81**, 363–380 (1977)
- Okabe, H., Gilden, R. V., Hatanaka, M., Stephenson, J. R., Gallagher, R. E., Gallo, R. C., Tronick, S. R., Aaronson, S. A.: *Nature* **260**, 264–266 (1976)
- Parks, W. P., Scolnick, E. M., Noon, M. C., Watson, C. J., Kawakami, T. G.: *Int. J. Cancer* **12**, 129–137 (1973)
- Pedersen, F. S., Haseltine, W. A.: *Methods in Enzymol.* (in Press)
- Reitz, M. S., Miller, N. R., Wong-Staal, F., Gallagher, R. E., Gallo, R. C., Gillespie, D. H.: *Proc. Natl. Acad. Sci. USA* **73**, 2113–2117 (1976)
- Rickard, C. G., Post, J. E., Noronha, F., Barr, L. M.: *JNCI* **42**, 987–995 (1969)
- Rommelaere, J., Faller, D. V., Hopkins, N.: *J. Virol.* **24**, 690–694 (1977)
- Rommelaere, J., Faller, D. V., Hopkins, N.: *Proc. Natl. Acad. Sci. USA* **75**, 495–499 (1978)
- Rowe, W.: *Cancer Res.* **33**, 3061–3068 (1973)
- Sarma, P. S., Log, T.: *Virology* **54**, 160–169 (1973)
- Sarma, P. S., Log, T., Jain, D., Hill, P. R., Huebner, R. J.: *Virology* **64**, 438–446 (1975)
- Scolnick, E. M., Parks, W., Kawakami, T., Kohne, D., Okabe, K., Gilden, R., Hatanaka, M.: *J. Virol.* **13**, 363–369 (1974)
- Scolnick, E. M., Parks, W. P., Todaro, G. J.: *Science* **177**, 1119–1121 (1972a)
- Scolnick, E. M., Parks, W. P., Todaro, G. J., Aaronson, S. A.: *Nature New Biol.* **235**, 34–40 (1972b)
- Snyder, S. P., Dungworth, D. L., Kawakami, T. G., Callaway, E., Lau, D.: *J. Natl. Cancer Inst.* **51**, 89–94 (1973)
- Teich, N. M., Weiss, R. A., Salahuddin, S. Z., Gallagher, R. E., Gillespie, D. H., Gallo, R. E.: *Nature* **256**, 551–555 (1975)
- Theilen, G. H., Gould, D., Fowler, M., Dungworth, D. L.: *J. Natl. Cancer Inst.* **47**, 881–889 (1971)
- Todaro, G. J., Lieber, M. M., Benveniste, R. E., Shur, C. J., Gibbs, C. J., Gajdusek, D. C.: *Virology* **67**, 335–357 (1975)
- Tooze, J. (ed.): *The Molecular Biology of Tumour Viruses*. Cold Spring Harbor, New York: Cold Spring Harbor 1973
- Tronick, S. R., Stephenson, J. R., Aaronson, S. A., Kawakami, T. G.: *J. Virol.* **15**, 115–120 (1975)
- Wang, L.-H., Duesberg, P.: *J. Virol.* **14**, 1515–1529 (1974)
- Wang, L.-H., Duesberg, P., Beeman, K., Vogt, P. F.: *J. Virol.* **16**, 1051–1070 (1975)